

LCD Monitor

Instructions for Use



LMD-2140MD

Owner's Record

The model and serial numbers are located at the rear. Record these numbers in the spaces provided below. Refer to these numbers whenever you call upon your Sony dealer regarding this product.

Model No. _____
Serial No. _____

WARNING

To prevent fire or shock hazard, do not expose the unit to rain or moisture.

Dangerously high voltages are present inside the unit. Do not open the cabinet. Refer servicing to qualified personnel only.

In the event of a malfunction or when maintenance is necessary, consult an authorized Sony dealer.

This unit contains substances which can pollute the environment if disposed carelessly. Please contact our nearest representative office or your local environmental office in case of disposal of this unit.

WARNING
THIS APPARATUS MUST BE EARTHED.

FOR CUSTOMERS IN EUROPE

This equipment has been found to comply with limits for a Class B device pursuant to EN60601-1-2. However, if this equipment does cause harmful interference to other devices, which can be determined by turning this equipment off and on, the user is encouraged to try to correct the interference by one or more of the following measures:

- Increase the separation between the equipment and other devices.
- Connect the equipment into an outlet on a circuit different from that to which other devices are connected.
- Consult the dealer or an experienced radio/TV technician for help.

For the customers in Europe

This product with the CE marking complies with both the EMC Directive (89/336/EEC) and the Low Voltage Directive (73/23/EEC) issued by the Commission of the European Community.

Compliance with these directives implies conformity to the following European standards:

EN60950-1 : Product Safety

EN55103-1 : Electromagnetic Interference (Emission)

EN55103-2 : Electromagnetic Susceptibility (Immunity)

This product is intended for use in the following Electromagnetic Environment(s):

E1 (residential), E2 (commercial and light industrial), E3 (urban outdoors), E4 (controlled EMC environment, ex. TV studio)

For the customers in Canada

This unit has been certified according to Standard CSA C22.2 NO.601.1.

FOR THE CUSTOMERS IN THE USA

This equipment has been tested and found to comply with the limits for a Class A digital device, pursuant to Part 15 of the FCC Rules. These limits are designed to provide reasonable protection against harmful interference when the equipment is operated in a commercial environment. This equipment generates, uses, and can radiate radio frequency energy and, if not installed and used in accordance with the instruction manual, may cause harmful interference to radio communications. Operation of this equipment in a residential area is likely to cause harmful interference in which case the user will be required to correct the interference at his own expense.

You are cautioned that any changes or modifications not expressly approved in this manual could void your authority to operate this equipment.

This product contains mercury. Disposal of this product may be regulated if sold in the United States. For disposal or recycling information, please contact your local authorities or the Electronics Industries Alliance (www.eiae.org <http://www.eiae.org>).

Be sure to connect the AC power cord to a grounded outlet.
--

Important safeguards/notices for use in the medical environments

1. All the equipment connected to this unit shall be certified according to Standard IEC60601-1, IEC60950-1, IEC60065 or other IEC/ISO Standards applicable to the equipment.
2. When this unit is used together with other equipment in the patient area*, the equipment shall be either powered by an isolation transformer or connected via an additional protective earth terminal to system ground unless it is certified according to Standard IEC60601-1 and IEC60601-1-1.

* Patient Area

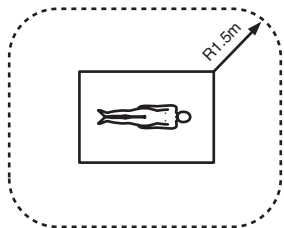







3. The leakage current could increase when connected to other equipment.
4. The operator should take precautions to avoid touching the rear panel input and output circuitry and the patient at the same time.
5. Model LMD-2140MD is a monitor intended for use in a medical environment to display pictures from cameras or other systems. These models are nonpatient care equipment with respect to the requirement of leakage current.

Caution

When you dispose of the unit or accessories, you must obey the law in the relative area or country and the regulation in the relative hospital.

Symbols on the unit

Symbol	Location	This symbol indicates
	Bottom	Main power switch. Press to turn the monitor on.
	Bottom	Main power switch. Press to turn the monitor off.
	Bottom	The equipotential terminal which brings the various parts of a system to the same potential.
	Bottom	Functional earth terminal
	Front	Brightness control
	Front	Contrast control
	Front	Key inhibit The settings are locked so that they cannot be changed.

Warning on power connection

Use a proper power cord for your local power supply.

	The United States	Canada	Continental Europe
Plug type	HOSPITAL GRADE	HOSPITAL GRADE	LP-34A
Female end	E41395	LL33182	LS-60
Cord type	E41395-A	LL76662	H05VV-F
Rated Voltage & Current	10A/125V	10A/125V	10A/250V
Safety approval	UL	CSA	VDE

AVERTISSEMENT

Afin d'éviter tout risque d'incendie ou d'électrocution, ne pas exposer cet appareil à la pluie ou à l'humidité.

Des courants de hautes tensions dangereuses sont présents à l'intérieur de cet appareil. Ne pas ouvrir le coffret. Se reporter à un personnel qualifié uniquement.

Dans le cas d'une défaillance ou de nécessité d'entretien, consulter un revendeur Sony autorisé.

Cet appareil contient des substances susceptibles de causer une pollution de l'environnement si elles sont éliminées de façon non conforme. Consultez votre bureau local de préservation de l'environnement pour savoir comment vous débarrasser de cet appareil.

**AVERTISSEMENT
CET APPAREIL DOIT ETRE RELIE A LA TERRE.**

POUR LES CLIENTS EN EUROPE

Cet équipement est conforme aux limitations d'un appareil de classe B ainsi qu'il est stipulé par la norme EN60601-1-2. Cependant, si cet équipement est la source d'interférences néfastes à d'autres appareils, ce qui peut être déterminé en mettant sous tension puis hors tension cet appareil, l'utilisateur est invité à essayer d'éliminer ces interférences en appliquant une ou plusieurs des mesures suivantes :

- Eloignez l'appareil des autres appareils.
- Raccordez l'appareil sur la prise d'un autre circuit que celui auquel les autres appareils sont raccordés.
- Consultez votre revendeur ou un technicien spécialisé en radio/TV pour obtenir de l'aide..

Raccordez le cordon d'alimentation à une prise murale mise à la terre.

Pour les clients européens

Ce produit portant la marque CE est conforme à la fois à la Directive sur la compatibilité électromagnétique CEM (89/336/CEE) et à la Directive sur les basses tensions (73/23/CEE) émises par la Commission de la Communauté européenne.

La conformité à ces directives implique la conformité aux normes européennes suivantes :

EN60950-1 : Sécurité des produits

EN55103-1 : Interférences électromagnétiques (émission)

EN55103-2 : Sensibilité électromagnétique (immunité)

Ce produit est prévu pour être utilisé dans les environnements électromagnétiques suivants:

E1 (résidentiel), E2 (commercial et industrie légère), E3 (urbain extérieur) et E4 (environnement CEM contrôlé, p. ex. studio de télévision)

Pour les clients au Canada

Cette unité a été certifiée conformément à la norme CSA C22.2 NO.601.1.

Précautions/instructions importantes pour une utilisation dans des environnements médicaux

1. Tous les équipements raccordés à cet appareil doivent être agréés conformément aux normes IEC60601-1, IEC60950-1, IEC60065 ou aux autres normes IEC/ISO applicables à ces équipements.
2. Si cet appareil est utilisé conjointement avec d'autres appareils à proximité du patient*, l'équipement doit être alimenté par un transformateur d'isolement ou raccordé via une borne de mise à la terre supplémentaire pour relier le système à la masse à moins qu'il ne soit certifié conforme aux normes IEC60601-1 et IEC60601-1-1.

* Proximité du patient

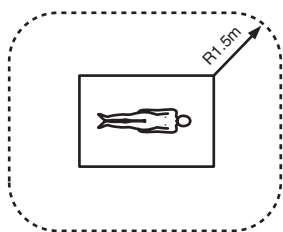

3. Le courant de fuite peut augmenter si raccordé à d'autres équipements.
4. L'opérateur doit prendre toutes les précautions requises pour ne pas toucher en même temps le patient et les circuits d'entrée et de sortie du panneau arrière.
5. Le modèle LMD-2140MD est un moniteur destiné à être utilisé en milieu médical pour la visualisation d'images transmises par des caméras ou d'autres systèmes. Ces modèles ne sont pas destinés au traitement des patients en ce qui concerne les exigences liées au courant de fuite.

Avertissement

Lors de l'élimination de l'appareil et de ses accessoires, vous devez vous conformer aux dispositions légales en vigueur dans votre région ou pays ainsi qu'au règlement de l'hôpital.

Symboles sur l'appareil

Symbole	Emplacement	Signification du symbole
	En bas	Interrupteur d'alimentation. Appuyez sur cette touche pour mettre le moniteur sous tension.
	En bas	Interrupteur d'alimentation. Appuyez sur cette touche pour mettre le moniteur hors tension.
	En bas	Borne équipotentielle qui ramène les différentes parties d'un système à la même tension.
	En bas	Borne de mise à la terre fonctionnelle
	Panneau avant	Commande de luminosité
	Panneau avant	Commande de contraste
	Panneau avant	Invalidation de touche Les réglages sont verrouillés et ne peuvent être modifiés.

Avertissement concernant le raccordement au secteur

Utilisez un cordon d'alimentation adapté à la tension secteur.

	The United States	Canada	Europe continentale
Type de fiche	TYPE HÔPITAL	TYPE HÔPITAL	LP-34A
Extrémité femelle	E41395	LL33182	LS-60
Type de cordon	E41395-A	LL76662	H05VV-F
Intensité nominale minimum du cordon	10A/125V	10A/125V	10A/250V
Certification de sécurité	UL	CSA	VDE

WARNUNG

Um Feuergefahr und die Gefahr eines elektrischen Schlages zu vermeiden, darf das Gerät weder Regen noch Feuchtigkeit ausgesetzt werden.

Im Inneren des Geräts liegt gefährliche Hochspannung an. Öffnen Sie niemals das Gehäuse und überlassen Sie Wartungsarbeiten stets nur einem Fachmann.

Sollten am Gerät Probleme auftreten oder eine Wartung erforderlich werden, wenden Sie sich an einen autorisierten Sony-Händler.

Dieses Gerät enthält Substanzen, die bei unsachgemäßer Entsorgung die Umwelt belasten. Bitte wenden Sie sich an unsere nächste Niederlassung oder an Ihr Umweltschutzamt, wenn Sie das Gerät entsorgen wollen.

**WARNUNG
DIESES GERÄT MUSS GEERDET WARDEN.**

FÜR KUNDEN IN EUROPA

Dieses Gerät erfüllt die nach EN60601-1-2 für Geräte der Klasse B geltenden Grenzwerte. Sollte dieses Gerät jedoch andere Geräte stören (Sie können dies feststellen, indem Sie das Gerät aus- und wieder einschalten), so ist der Benutzer dazu angehalten, die Störungen durch eine der folgenden Maßnahmen zu beheben:

- Vergrößerung des Abstands zwischen diesem Gerät und anderen Geräten.
- Anschluss des Geräts an einen anderen Stromkreis als den der anderen Geräte.
- Ziehen Sie gegebenenfalls Ihren Händler oder einen erfahrenen Rundfunk- oder Fernsehtechniker zu Rate.

Schließen Sie das Netzkabel unbedingt an eine geerdete Netzsteckdose an.

Für Kunden in Europa

Dieses Produkt besitzt die CE-Kennzeichnung und erfüllt sowohl die EMV-Direktive (89/336/EEC) als auch die Direktive Niederspannung (73/23/EEC) des Rats der europäischen Gemeinschaft.

Die Erfüllung dieser Direktiven bedeutet Konformität für die folgenden Europäischen Normen:

EN60950-1: Produktsicherheit

EN55103-1: Elektromagnetische Interferenz(Emission)

EN55103-2: Elektromagnetische Empfindlichkeit (Immunität)

Dieses Produkt ist für den Einsatz unter folgenden elektromagnetischen Bedingungen ausgelegt:

E1 (Wohnbereich), E2 (kommerzieller und in

beschränktem Maße industrieller Bereich), E3

(Stadtbereich im Freien) und E4 (kontrollierter EMV - Bereich, z. B. Fernsehstudio)

Maschinenlärminformations - Verordnung 3.GPSGV, 06.01.2004: Der höchste Schalldruckpegel beträgt 70 dB(A) oder weniger gemäß EN ISO 7779.

Wichtige Sicherheitshinweise für die Verwendung des Geräts in der Medizin

1. Alle Geräte, die an dieses Gerät angeschlossen werden, müssen den Normen IEC60601-1, IEC60950-1, IEC60065 und anderen für die jeweiligen Geräte gültigen IEC/ISO-Normen entsprechen.
2. Wenn dieses Gerät zusammen mit anderen Geräten im Patientenbereich* eingesetzt wird, muss es entweder über einen Isoliertransformator mit Strom versorgt oder über einen zusätzlichen Schutzerdungsanschluss gesichert sein, es sei denn, es entspricht den Normen IEC60601-1 und IEC60601-1-1.

* Für Patienten zugänglicher Bereich

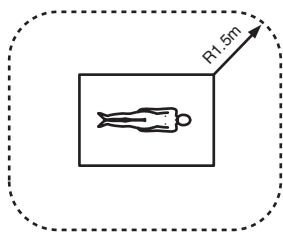





3. Der Ableitstrom kann bei einer Verbindung mit anderen Geräten zunehmen.
4. Der Anwender muss Maßnahmen treffen, um gleichzeitiges Berühren der Ein- und Ausgangskontakte an der Rückseite des Gerätes und des Patienten zu verhindern.
5. Das Modell LMD-2140MD ist ein Monitor für den medizinischen Bereich und dient dazu, Bilder von Kameras oder anderen Systemen anzuzeigen. Aufgrund der Bestimmungen im Hinblick auf Kriechströme gelten diese Modelle als Geräte, die nicht zur Versorgung von Patienten geeignet sind.

Vorsicht

Wenn Sie das Gerät oder die Zubehörteile entsorgen, beachten Sie unbedingt die gesetzlichen Vorschriften in der jeweiligen Region bzw. im jeweiligen Land sowie die Vorschriften im jeweiligen Krankenhaus.

Symbole am Gerät

Symbol	Befindet sich	Bedeutung
	an der Unterseite	Hauptnetzschalter. Zum Einschalten des Monitors
	an der Unterseite	Hauptnetzschalter. Zum Ausschalten des Monitors.
	an der Unterseite	Äquipotenzialanschluss, der die Spannung der verschiedenen Systemkomponenten aneinander angleicht.
	an der Unterseite	Funktionaler Massepol
	an der Vorderseite	Helligkeitsregelung
	an der Vorderseite	Kontrastregelung
	an der Vorderseite	Tastensperre Die Einstellungen sind gesperrt und können nicht verändert werden.

Warnhinweis zum Netzanschluss

Verwenden Sie ein für die Stromversorgung in Ihrem Land geeignetes Netzkabel.

	USA	Kanada	Kontinentaleuropa
Steckertyp	HOSPITAL GRADE	HOSPITAL GRADE	LP-34A
Buchse	E41395	LL33182	LS-60
Kabeltyp	E41395-A	LL76662	H05VV-F
Nennspannung & Stromstärke	10A/125V	10A/125V	10A/250V
Sicherheitszertifizierung	UL	CSA	VDE

ADVERTENCIA

Para evitar incendios o el riesgo de electrocución, no exponga la unidad a la lluvia ni a la humedad.

Dentro de la unidad existen altas tensiones peligrosas. No la abra. En caso de avería, solicite los servicios de personal cualificado.

En caso de mal funcionamiento o cuando sea necesario el servicio de mantenimiento, consulte a su proveedor Sony.

Esta unidad contiene sustancias que pueden contaminar el medio ambiente si no se desecha adecuadamente. Póngase en contacto con nuestro departamento de representación más próximo o con el departamento local de medio ambiente cuando vaya a desechar esta unidad.

**ADVERTENCIA
ESTA APPARATO DEBE CONECTARSE A
TIERRA.**

PARA LOS USUARIOS EN EUROPA

Este equipo cumple con los límites de dispositivo de Clase B según EN60601-1-2. No obstante, si este equipo causa interferencias perjudiciales para otros dispositivos, lo que puede comprobarse apagando y encendiendo este equipo, se recomienda al usuario corregir las interferencias realizando una o varias de las siguientes medidas:

- Aumentar la separación entre el equipo y los demás dispositivos.
- Conectar el equipo a una toma de un circuito diferente al que estén conectados los demás dispositivos.
- Consultar con el proveedor o solicitar los servicios de un técnico especializado en radio y TV.

Asegúrese de conectar el cable de alimentación de CA a una toma de tierra.

Para los clientes del mercado europeo

Este producto cumple con las directivas de compatibilidad electromagnética (89/336/CEE) y baja tensión (73/23/CEE) de la Comisión Europea.

El cumplimiento de estas directivas implica la conformidad con los siguientes estándares europeos:

EN60950-1: Seguridad del producto

EN55103-1: Interferencias electromagnéticas (emisiones)

EN55103-2: Susceptibilidad electromagnética (inmunidad).

Este producto está diseñado para funcionar en los siguientes entornos electromagnéticos:

E1 (doméstico), E2 (comercial y pequeña industria), E3

(espacios al aire libre fuera de poblaciones) y E4

(entorno con compatibilidad electromagnética controlada; por ejemplo, en un estudio de TV).

Protecciones de seguridad/advertencias importantes de uso en entornos médicos

1. Todos los equipos conectados a esta unidad deben cumplir las normas IEC60601-1, IEC60950-1, IEC60065 u otras normas IEC/ISO aplicables a los equipos.
2. Si esta unidad se utiliza junto con otro equipo en la zona de pacientes*, dicho equipo debe alimentarse con un transformador de aislamiento, o conectarse mediante un terminal de tierra de protección adicional a un sistema de toma de tierra, a no ser que cumpla las normas IEC60601-1 y IEC60601-1-1.

* Zona de pacientes

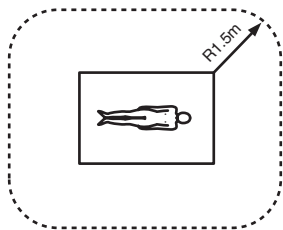

3. La corriente de fugas podría aumentar si se conecta a otro equipo.
4. El operador debe tomar las precauciones pertinentes para evitar tocar la entrada del panel posterior y la circuitería de salida y al paciente al mismo tiempo.
5. El modelo LMD-2140MD es un monitor destinado a utilizarse en entornos médicos para visualizar imágenes de cámaras u otros sistemas. Estos modelos no son equipos de atención sanitaria hospitalaria en lo que al requisito de corriente de fuga se refiere.

Precaución

Al desechar la unidad o sus accesorios, se debe cumplir la ley de la zona o país correspondiente y la normativa del hospital correspondiente.

Símbolos de la unidad

Símbolo	Ubicación	Este símbolo indica
	Parte inferior	Interruptor de alimentación principal. Púlselo para encender el monitor.
	Parte inferior	Interruptor de alimentación principal. Púlselo para apagar el monitor.
	Parte inferior	El terminal equipotencial que iguala el potencial de los distintos componentes de un sistema.
	Parte inferior	Terminal de tierra funcional
	Panel frontal	Control de brillo
	Panel frontal	Mando de contraste
	Panel frontal	Inhibición de teclas Los ajustes están bloqueados, de modo que no se pueden modificar.

Advertencia sobre la conexión de alimentación

Utilice un cable de alimentación adecuado al suministro eléctrico local.

	Estados Unidos	Canadá	Europa continental
Tipo de enchufe	TIPO PARA HOSPITAL	TIPO PARA HOSPITAL	LP-34A
Extremo hembra	E41395	LL33182	LS-60
Tipo de cable	E41395-A	LL76662	H05VV-F
Corriente y tensión nominal	10A/125V	10A/125V	10A/250V
Aprobación de seguridad	UL	CSA	VDE

AVVERTENZA

Per evitare incendi o cortocircuiti, l'apparecchio non deve essere esposto alla pioggia o all'umidità.

All'interno del televisore sono presenti tensioni pericolosamente alte. Non aprire l'apparecchio. Per le riparazioni, rivolgersi esclusivamente a personale specializzato.

Nel caso di malfunzionamenti o di necessarie riparazioni dell'apparecchio, consultare un rivenditore autorizzato Sony.

Questo apparecchio contiene sostanze che possono inquinare l'ambiente se non vengono smaltite con le dovute cautele. Per informazioni sulle normative in caso di smaltimento di questo apparecchio, si prega di contattare il nostro rappresentante locale o il centro di informazioni ambientali di zona.

**AVVERTENZA
QUESTO APPARECCHIO DEVE ESSERE
COLLOGATO A MASSA.**

PER I CLIENTI IN EUROPA

Questo apparecchio è stato progettato rispettando le norme per i dispositivi di Classe B in conformità agli standard EN60601-1-2. Tuttavia, se durante l'accensione o lo spegnimento il presente apparecchio dovesse provocare interferenze dannose ad altri dispositivi, l'utente è tenuto a correggere tali interferenze adottando le seguenti precauzioni:

- Aumentare la distanza tra l'apparecchio e gli altri dispositivi.
- Collegare l'apparecchio ad una presa di rete o ad un circuito diverso da quello utilizzato per collegare gli altri dispositivi.
- Consultare il rivenditore o un tecnico radio/TV specializzato per risolvere eventuali problemi.

Assicurarsi di collegare il cavo di alimentazione CA ad una presa con messa a terra.

Per i clienti in Europa

Questo prodotto recante il marchio CE è conforme sia alla direttiva sulla compatibilità elettromagnetica (EMC) (89/336/CEE) che alla direttiva sulle basse tensioni (73/23/CEE) emesse dalla Commissione della Comunità Europea.

La conformità a queste direttive implica la conformità alle seguenti normative europee:

EN60950-1: Sicurezza dei prodotti

EN55103-1: Interferenza elettromagnetica (Emissione)

EN55103-2: Sensibilità ai disturbi elettromagnetici (Immunità)

Questo prodotto è destinato all'uso nei seguenti ambienti elettromagnetici:

E1 (residenziale), E2 (commerciali e industriali leggeri), E3 (esterni urbani) e E4 (ambienti EMC controllati, ad esempio studi televisivi).

Informazioni importanti per la sicurezza nell'uso in ambiente sanitario

1. Tutte le apparecchiature collegate a questo apparecchio dovranno essere in possesso di certificazione in conformità alle norme IEC60601-1, IEC60950-1, IEC60065 o altre norme IEC/ISO applicabili.
2. In caso di utilizzo insieme ad altre apparecchiature in aree destinate a pazienti* l'apparecchio dovrà essere dotato di trasformatore oppure dovrà essere collegato mediante un terminale di terra supplementare all'impianto di messa a terra, a meno che già in possesso di certificazione conforme alla norme IEC60601-1 e IEC60601-1-1.

* Aree destinate a pazienti

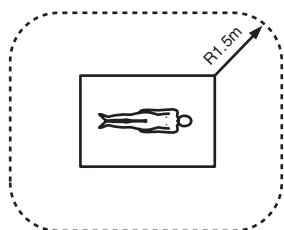







3. La corrente di dispersione può aumentare se collegato ad altre apparecchiature.
4. L'operatore deve fare attenzione a non toccare contemporaneamente i circuiti di entrata e uscita del pannello posteriore e il paziente.
5. Il modello LMD-2140MD è un monitor concepito per l'impiego nel settore medico. Serve a visualizzare immagini provenienti da videocamere o da altri sistemi video. Questi modelli non sono progettati per le aree di cura dei pazienti per quanto riguarda le norme relative alla dispersione di corrente.

Attenzione

In fase di smaltimento dell'unità o degli accessori, rispettare la legislazione locale o le normative vigenti sul luogo di lavoro.

Simboli sull'apparecchio

Simbolo	Posizione	Significato
	Lato inferiore	Interruttore principale di alimentazione. Premere questo tasto per accendere il monitor.
	Lato inferiore	Interruttore principale di alimentazione. Premere questo tasto per spegnere il monitor.
	Lato inferiore	Terminale equipotenziale che porta le varie parti di un sistema allo stesso livello.
	Lato inferiore	Terminale funzionale di terra
	Pannello anteriore	Controllo luminosità
	Pannello anteriore	Controllo contrasto
	Pannello anteriore	Inibizione tasto Le impostazioni vengono bloccate per impedirne la modifica.

Avvertenza sul collegamento dell'alimentazione

Utilizzare un cavo di alimentazione adeguato all'alimentazione del Paese in cui ci si trova.

	Stati Uniti	Canada	Europa continentale
Tipo di spina	PER L'USO IN OSPEDALE	PER L'USO IN OSPEDALE	LP-34A
Terminale femmina	E41395	LL33182	LS-60
Tipo di cavo	E41395-A	LL76662	H05VV-F
Tensione e corrente nominale	10A/125V	10A/125V	10A/250V
Approvazione di sicurezza	UL	CSA	VDE

警告

为了防止电击伤害，请不要将此设备暴露在雨中或潮湿的环境中。

此设备内部有高压电，请勿打开机壳。如果设备出现故障请专业人员负责维修。

如果设备需要维修或维护，请联系授权的 Sony 经销商。







如果此设备处置不当，它含有的物质会对环境造成污染。如果需要处理此设备，请联系当地的代表处或环境部门。

警告

此设备必须良好接地。

请将 AC 电源线连接到有接地的插座中。

设备上的符号

符号	位置	符号含义
	底部	主电源开关。 按一下此开关打开监视器。
	底部	主电源开关。 按一下此开关关闭监视器。
	底部	使系统所有部件保持同一电位的等电位接地端子。
	底部	功能接地端子
	前面	亮度控制
	前面	对比度控制
	前面	锁定键 您可以将设置锁定，这样可以防止对其进行修改。

警告

若要避免起火或電擊危險，請勿將本機器曝露在雨中或潮濕環境中。

機器內部有危險高電壓。請勿開啟機殼。請僅由合格的維修人員進行維修。

若發生故障或需要維修時，請洽授權的 Sony 經銷商。







本機器包含可能污染環境的物質，必須小心處理。請聯絡您最近的代表辦公室或當地的環保機關，來洽詢棄置處理本機器的事宜。

警告

此設備必須接地線。

請確定 AC 電源線連接至有接地的電源插座。

產品上的符號

符號	位置	符號意義
	底部圖	主電源開關。 按下即可開啟設備電源。
	底部圖	主電源開關。 按下即可關閉設備電源。
	底部圖	等電位終端使設備各部件的電位相等。
	底部圖	功能接地終端
	正面圖	亮度控制鈕
	正面圖	對比控制鈕
	正面圖	按鍵抑制 鎖住設定值，以避免變更它們。

경고

화재나 감전 위험을 방지하려면 장치가 물기나 습기에 노출되지 않도록 하십시오.

장치 내부에는 고압이 사용되므로 위험합니다. 절대 본체를 열지 마십시오. 자격 있는 전문 정비 요원만 서비스를 실시해야 합니다.

오동작이 발생하거나 유지 보수가 필요하면 Sony 공인 대리점에 문의하십시오.

이 장치에는 부주의하게 폐기할 경우 환경을 오염시킬 수 있는 물질이 포함되어 있습니다. 이 장치를 폐기할 경우에는 가까운 당사 서비스 센터나 지역 폐기물 처리 센터에 문의하십시오.

경고

이 장치는 접지되어야만 합니다.

AC 전원 코드는 접지 콘센트에 확실히 연결되어 있어야 합니다.

이 기기는 업무용으로 전자파적합등록을 한 기기이오니 판매자 또는 사용자는 이 점을 주의하시기 바라며 만약 잘못 판매 또는 구입하였을 때에는 가정용으로 교환하시기 바랍니다.

장치 상의 기호





기호	위치	기호의 의미
	하단	주 전원 스위치. 이 스위치를 눌러 모니터를 켭니다.
	하단	주 전원 스위치. 이 스위치를 눌러 모니터를 끕니다.
	하단	시스템의 여러 부분을 동일한 전위로 만드는 등전위 단자입니다.
	하단	접지 단자
	전면	밝기 조정
	전면	컨트라스트 조정
	전면	키 조작 금지 설정이 변경되지 않도록 록크됩니다.

Table of Contents

Precaution	16
On Safety	16
On Installation	16
About the LCD Display Panel	16
About the Fluorescent Tube	16
On Cleaning	16
Disposal of the Unit	17
Recommendation to Use more than One Unit ..	17
On Repacking	17
On Fan Error	17
Features	17
Location and Function of Parts and Controls ..	19
Front Panel	19
Input Signals and Adjustable/Setting Items	21
Bottom	22
Connecting the AC Power Cord	23
Attaching the Input Adaptor	24
Selecting the Default Settings	24
Selecting the Menu Language	26
Using the Menu	27
Loading USER MEMORY	28
Adjustment Using the Menus	28
Items	28
Adjusting and Changing the Settings	29
STATUS menu.....	29
COLOR TEMP menu.....	30
USER CONTROL menu.....	30
USER CONFIG menu.....	32
REMOTE menu	33
USER MEMORY menu.....	33
Saving the user memory.....	34
INPUT SELECT menu	35
KEY INHIBIT menu.....	35
USER SERVICE menu	35
Troubleshooting	36
Specifications	36
Dimensions/Mass	42

Precaution

On Safety

- Operate the unit on 100 – 240 V AC only.
- The nameplate indicating operating voltage, etc. is located on the rear.
- Should any solid object or liquid fall into the cabinet, unplug the unit and have it checked by qualified personnel before operating it any further.
- Unplug the unit from the wall outlet if it is not to be used for several days or more.
- To disconnect the AC power cord, pull it out by grasping the plug. Never pull the cord itself.
- The socket-outlet shall be installed near the equipment and shall be easily accessible.

On Installation

- Prevent internal heat build-up allowing adequate air circulation.
Do not place the unit on surfaces (rugs, blankets, etc.) or near materials (curtains, draperies) that may block the ventilation holes.
- Do not install the unit near heat sources such as radiators or air ducts, or in a place subject to direct sunlight, excessive dust, mechanical vibration or shock.
- Do not place the monitor near equipment which generates magnetism, such as a transformer or high voltage power lines.
- When you install the unit to a wall, ceiling, mount arm or operating light, consult to qualified personnel.

About the LCD Display Panel

- Although the LCD display panel is made with high-precision technology, black dots may appear or bright points of light (red, blue, or green) may appear constantly on the LCD screen. And a color shade or bight shade may appear according to a viewing angle. These are structural properties of the LCD panel and are not malfunctions.
- The LCD screen is made with high-precision technology and more than 99.99% of the picture element is intact. However, some of the picture element may not appear or some of the picture element may appear constantly.
- Do not leave the LCD screen facing the sun as it can damage the LCD screen. Take care when you place the unit by a window.
- Do not push or scratch the LCD monitor's screen. Do not place a heavy object on the LCD monitor's screen. This may cause the screen to lose uniformity.

- If the unit is used in a cold place, a residual image may appear on the screen. This is not a malfunction. When the monitor becomes warm, the screen returns to normal.
- If a still picture is displayed for a long time, a residual image may appear. The residual image will eventually disappear.
- The screen and the cabinet become warm during operation. This is not a malfunction.

About the Fluorescent Tube

- A specially designed fluorescent tube is installed as the lighting apparatus for this unit. If the LCD screen becomes dark, unstable or does not turn on, consult your Sony dealer.

On Cleaning

Before cleaning

Be sure to disconnect the AC power cord from the AC outlet.

On cleaning the monitor

A material that withstands sterilization is used for the front protection plate of the medical use LCD monitor. The protection plate surface is especially treated to reduce reflection of light. When solvents such as benzene or thinner, or acid, alkaline or abrasive detergent, or chemical cleaning cloth are used for the protection plate surface/monitor surface, the performance of the monitor may be impaired or the finish of the surface may be damaged. Take care with respect to the following:

- Clean the protection plate surface/monitor surface with a 50 to 70 v/v% concentration of isopropyl alcohol or a 76.9 to 81.4 v/v% concentration of ethanol using a swab method. Wipe the protection plate surface gently (wipe using less than 1 N force).
- Stubborn stains may be removed with a soft cloth such as a cleaning cloth lightly dampened with mild detergent solution using a swab method and then clean using the above chemical solution.
Never use solvents such as benzene or thinner, or acid, alkaline or abrasive detergent, or chemical cleaning cloth for cleaning or sterilization, as they will damage the protection plate surface/monitor surface.
- Do not use unnecessary force to rub the protection plate surface/monitor surface with a stained cloth. The protection plate surface/monitor surface may be scratched.
- Do not keep the protection plate surface/monitor surface in contact with a rubber or vinyl resin product for a long period of time. The finish of the surface may deteriorate or the coating may come off.

Disposal of the Unit

- Do not dispose of the unit with general waste.
Do not include the monitor with household waste.
- The fluorescent tube includes mercury. Dispose of the monitor in accordance with the regulations of your local sanitation authority.

Recommendation to Use more than One Unit

- As problems can occasionally occur for the monitor, when the monitor is used for safety control of personnel, assets or stable picture, or for emergencies, we strongly recommend you use more than one unit or prepare a spare unit.

On Repacking

- Do not throw away the carton and packing materials. They make an ideal container which to transport the unit.
If you have any questions about this unit, contact your authorized Sony dealer.

On Fan Error

- The fan for cooling the unit is built in. When the "FAN ERROR" message is displayed, turn off the power and contact an authorized Sony dealer.

Features

Compliance of safety standards in America, Canada and Europe

UL60601-1 for America, CSA C22.2 No.601.1 for Canada and EN 60601-1 for Europe have been obtained for this monitor.

The monitor is designed for easy maintenance, with the sheet switch, screen protect panel, etc.

Picture

Sophisticated I/P (Interlace to Progressive) Conversion

The LMD-2140MD provides sophisticated I/P conversion with Sony's original X-Algorithm technology. This technology combines the pixels above, below and in the diagonal direction of the moving picture part, and then inserts a natural pixel.

The direct result is much smoother image reproduction for both moving and static picture areas.

Full digital image processing circuitry

As well as digital signals, all signals including analog signals are converted into digital signals without any deterioration in the pictures via a full digital image processing circuitry.

Two color system available

The monitor can display NTSC and PAL signals by connecting this unit. The appropriate color system is selected automatically.

Auto chroma/phase function

The chroma and phase of the decoder are automatically adjusted with the auto chroma phase function.

High-quality LCD panel

Because the monitor uses high brightness, high resolution and ultra-wide viewing angle technology, the monitor can be used under various lighting conditions and in numerous ways (hanging on the wall, several ways of monitoring the picture, etc.).

Because a color filter with wide-color reproduction and LCD materials with high response speed are used, the motion picture of the video signal is displayed clearer.

Input

Accepts analog RGB input signals

Adopting the scan converter allows this monitor to detect VGA, SVGA, XGA and SXGA analog RGB signals input to the HD15 input connector.

Accepts DVI-D (digital) input signals

Adopting the scan converter allows this monitor to detect VGA, SVGA, XGA and SXGA digital computer signals input to the DVI input connector.

To view SXGA signals when the DVI input is selected, use the cable within 3 m (118 1/8 inches) in length.

Optional slot for the video signal

Two optional input adaptors can be attached. The composite, Y/C, component, analog RGB, SDI or DV signal can be input depending on the input connectors of the board to be used.

Multi-format

NTSC or PAL color system or DTV format, such as 720P, 1080I, etc. can be selected automatically.

External sync input

The unit can be operated on the sync signal supplied from an external sync generator.

Functions

APA (Auto Pixel Alignment) function

You can display pictures from the HD 15 input connector in the appropriate size by simply pressing the APA key.

Automatic termination (connector with mark only)

The input connector is terminated internally at 75 ohms when nothing has been connected to the output connector. If a cable is connected to the output connector, the internal terminal is automatically released and the signals input to the input connector are output to the output connector (loop-through).

Select color temperature and gamma mode

You can select the color temperature from among four (HIGH, LOW, LOW2, LOW3) settings and gamma mode from among five settings. You can also adjust the color temperature to the appropriate setting in "USER".

Aspect setting

You can set the monitor to 4:3 or 16:9 display mode according to the input signal.

Scan function

You can select the display from among "NORMAL", "UNDER", "OVER", "ZOOM" and "NATIVE (NTSC, PAL, 480/60I and 575/50I only)".

Select language display

You can select your language for the display from seven languages - English, German, French, Italian, Spanish, Japanese and Chinese.

Power saving function

The monitor enters into power saving mode to reduce the power consumption when no signal is input.

Key inhibit function

You can inhibit the key to prevent missing an operation.

User memory function

You can save the 20 picture settings with the name. The user memory data can be saved or loaded between the monitor and the equipment (PC, etc.) connected in serial remote mode.

Two kinds of ground terminals

Two kinds of ground terminals are built into the monitor to equal the electric potential.

External remote control function

You can directly select the input signal, aspect, etc. by operating the connected equipment.

Other

Optional stand

It is more convenient to install the monitor on a desk by using the optional stand (SU-560).

Location and Function of Parts and Controls

Front Panel

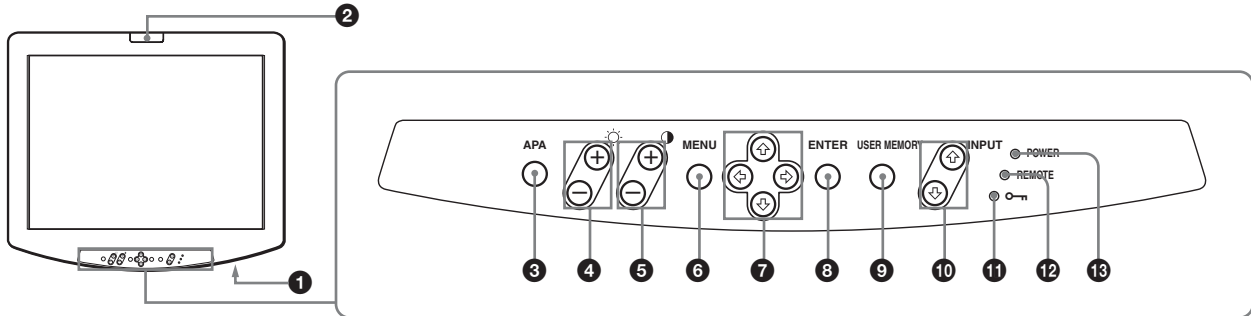

1 I/O (Power) switch

Press **I** to turn on the power and **O** to turn off the power. When the power is turned on, the POWER indicator lights.

2 Tally lamp

The lamp lights by the connection to control the tally. For details, refer to “Pin assignment” on page 38.

3 APA (Auto Pixel Alignment) key

Adjust a picture clearest automatically while a signal is input from the HD15 input connector. To adjust the picture further for finer picture due to the input signal, see the “DOT PHASE” on page 32.

Press the MENU key to stop the APA operation. The APA function does not work when the menu is displayed.

4 (Brightness) +/- keys

+: press for more brightness.
-: press for less brightness.

The value is reset to the default setting by pressing the **+** and **-** keys simultaneously.

5 (Contrast) +/- keys

+: press to make the contrast stronger.
-: press to make the contrast weaker.

The value is reset to the default setting by pressing the **+** and **-** keys simultaneously.

6 MENU key

Press to display the on-screen menu. Press again to clear the menu.

The USER SERVICE menu (on page 35) appears by keeping the MENU key pressed.

For menu operations, refer to “Using the Menu” on page 27.

7 Arrow keys (↑/↓/←/→)

Select the menu or to make various adjustments.

8 ENTER key

Press to decide a selected item in the menu.

9 USER MEMORY key

Press to load the picture settings saved in the USER MEMORY menu (on page 33).

10 INPUT ↑/↓ keys

Select the input signal. Each time you press the **↑** key, the input signal switches as follows. When the **↓** key is pressed, the input signal switches in reverse order.

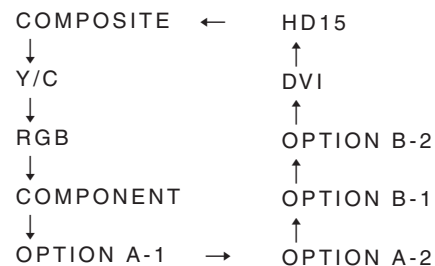

Notes

- The signal set to “OFF” in the INPUT SELECT menu is not selected with the INPUT key and skipped. To select the signal, select “ON”.
- When an input adaptor is not attached, “OPTION” is skipped automatically.

⑪ (Key inhibit) indicator

When the key inhibit function works, the indicator lights.

For the key inhibit function, refer to “REMOTE menu” on page 33 and “KEY INHIBIT menu” on page 35.

⑫ REMOTE indicator

When the serial remote (RS-232C) is operable, the indicator lights.

For the remote function, refer to “REMOTE menu” on page 33.

⑬ POWER indicator

When the power is turned on, the indicator lights in amber and then in green.

This indicator lights in amber in power saving mode.

Input Signals and Adjustable/Setting Items

Item	Input signal										
	Video* ¹ , Y/C* ¹	B & W* ¹	Component* ²		RGB* ²		SDI		DV* ⁵	DVI	HD15
			SD	HD	SD	HD	D1* ³	HD* ⁴			
CONTRAST	○	○	○	○	○	○	○	○	○	○	○
BRIGHT	○	○	○	○	○	○	○	○	○	○	○
CHROMA	○	×	○	○	×	×	○	○	○	×	×
PHASE	○ (NTSC)	×	×	×	×	×	×	×	×	×	×
APERTURE	○	○	○	○	×	×	○	○	○	×	×
COLOR TEMP	○	○	○	○	○	○	○	○	○	○	○
AUTO CHROMA/ PHASE	○	×	○	○	×	×	○	○	○	×	×
COMP LEVEL	×	×	○ (480/ 60I)	×	×	×	×	×	×	×	×
NTSC SETUP	○ (NTSC)	○ (480/60I)	×	×	×	×	×	×	×	×	×
GAMMA	○	○	○	○	○	○	○	○	○	○	○
SCAN* ⁶	○	○	○	○	○	○	○	○	○	×	×
ASPECT	○	○	○	×	○	×	○	×	○	×	×
APA	×	×	×	×	×	×	×	×	×	×	○
SIZE H	×	×	×	×	×	×	×	×	×	×	○
SHIFT	○	○	○	○	○	○	○	○	○	○	○
DOT PHASE	×	×	×	×	×	×	×	×	×	×	○
POWER SAVING	○	○	○	○	○	○	○	○	○	○	○
PIC DELAY MIN	○	○	○	×	○	×	○	×	○	×	×

○ : Adjustable/can be set

× : Not adjustable/cannot be set

*1 The signal can be input without an input adaptor.
When a BKM-227W is attached, a number of the input is increased.

*2 The signal can be input without an input adaptor.
When a BKM-229X is attached, a number of the input is increased.

*3 When a BKM-220D or BKM-243HS is attached, the signal can be input.

*4 When a BKM-243HS is attached, the signal can be input.

*5 When a BKM-255DV is attached, the signal can be input.

*6 You may not be able to set this item due to the input signal. For details, see “Scan mode image” on page 31.

Bottom

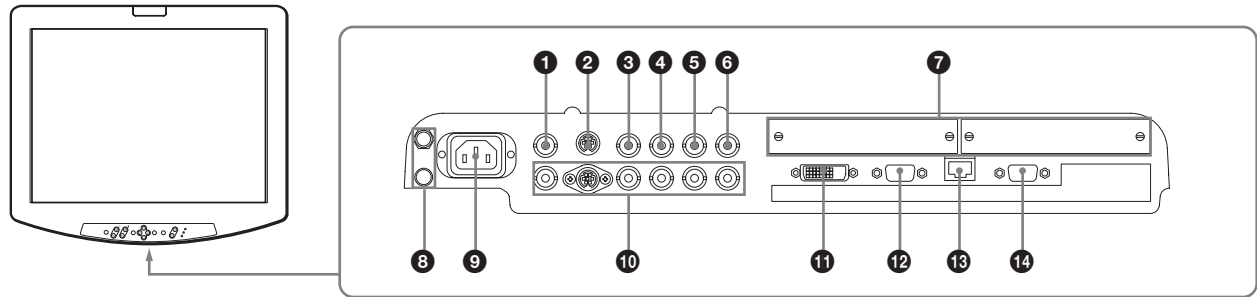

1 COMPOSITE connector (BNC)

Input connector for composite signals.

2 Y/C connector (4-pin mini-DIN)

Input connector for Y/C signals.

3 G/Y connector (BNC)

Input connector for component Y (luminance) and G of RGB signals.

4 B/P_B connector (BNC)

Input connector for P_B (blue color difference) of component signals and B of RGB signals.

5 R/P_R connector (BNC)

Input connector for P_R (red color difference) of component signals and R of RGB signals.

6 EXT SYNC (External sync) connector (BNC)

When this unit operates on an external sync signal, connect the reference signal from a sync generator to this connector.

Select "EXT" in "SYNC" of the USER CONFIG menu (on page 32) to use the sync signal through this connector.

Note

When inputting a video signal with the jitters, etc. the picture may be disturbed. We recommend using the TBC (time base corrector).

7 Optional input slots

An optional input adaptor can be attached according to your requirements. Press the INPUT key to select the signals.

8 ⚡/⏚ (Equipotential/Function Earth) terminal

⚡ (equipotential) terminal

Connects the equipotential plug.

⏚ (function earth) terminal

Connects the earth cable.

9 AC IN socket

Connect the supplied AC power cord.

10 Loop-through output connectors

The signals input to the input connectors (1, 2, 3, 4, 5 and 6) are output here. Connect to the equipment according to the input signal.

When the cable is connected to this connector, the 75-ohm termination of the input automatically released, and the signal from the input connector is output from this connector.

11 DVI input connector (DVI-D)

DVI Rev.1.0 applicable digital RGB signal is input.

To view SXGA signals when the DVI input is selected, use the cable within 3 m (118 1/8 inches) in length.

12 HD15 input connector (HD D-Sub 15 pin)

An analog RGB video signal (0.7 Vp-p, positive polarity) and sync signal are input.

The Plug & Play function corresponds to DDC2B.

13 PARALLEL REMOTE terminal (modular connector, 8-pin)

Connects a parallel switch and controls the monitor externally.

For safety, do not connect the connector for peripheral device wiring that might have excessive voltage to this modular connector.

For details on the pin assignment and factory setting function assigned to each pin, see "Pin assignment" on page 38.

14 SERIAL REMOTE (RS-232C) terminal (D-Sub 9 pin)

Connects to the RS-232C control connector on external equipment connected to the monitor. The monitor can be operated according to control commands sent from external equipment connected to it.

For details on the pin assignment and function assigned to each pin, see "Pin assignment" on page 38.

For details, refer to the Interface Manual for Programmers (saved in the supplied CD-ROM, Japanese and English only).

Connecting the AC Power Cord

Connect the supplied AC power cord as illustrated. The two AC plug holders are supplied. Use one of them that will securely hold the AC plug.

- 1 Plug the AC power cord into the AC IN socket on the rear panel. Then, attach the AC plug holder to the AC power cord.

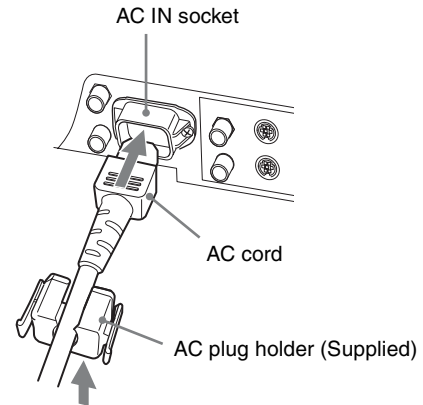

- 2 Slide the AC plug holder over the cord until it locks.

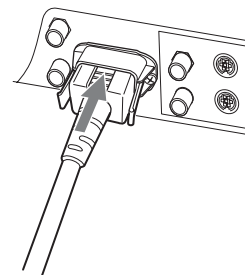

To remove the AC power cord

Pull out the AC plug holder while pressing the lock levers.

Attaching the Input Adaptor

Before attaching the input adaptor, disconnect the power cord.

Attach the input adaptor to the optional input slot after removing the panel of the slot.

- 1 Remove the panel of the optional input slot.

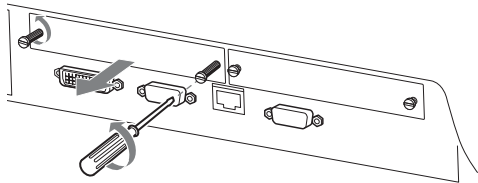

- 2 Insert the input adaptor into the slot.

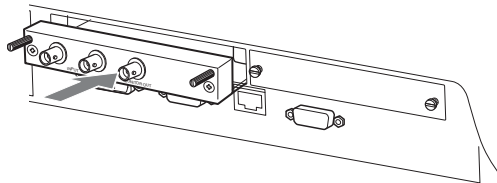

- 3 Tighten the screws.

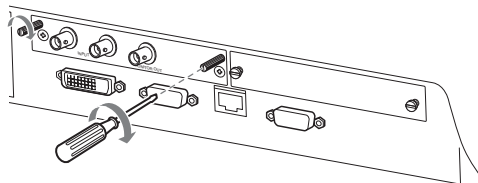

Selecting the Default Settings

When you turn on the unit for the first time after purchasing it, select the area where you intend to use this unit from among the options.

The default setting values for each area

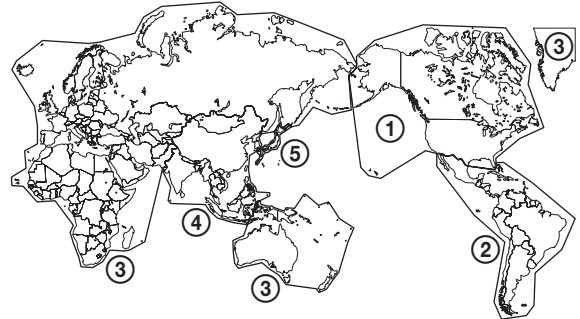

		COLOR TEMP	COMP LEVEL	NTSC SETUP
① NORTH AMERICA		Low	BETA7.5	7.5
② LATIN AMERICA	ARGENTINA	Low	SMPTE	0
	PARAGUAY	Low	SMPTE	0
	URUGUAY	Low	SMPTE	0
	NTSC&PAL-M AREA	OTHER AREA	Low	BETA7.5
③ AFRICA AUSTRALASIA EUROPE MIDDLE-EAST		Low	SMPTE	0
		Low	BETA7.5	7.5
④ ASIA EXCEPT JAPAN	NTSC AREA	Low	BETA7.5	7.5
	PAL AREA	Low	SMPTE	0
⑤ JAPAN		High	SMPTE	0

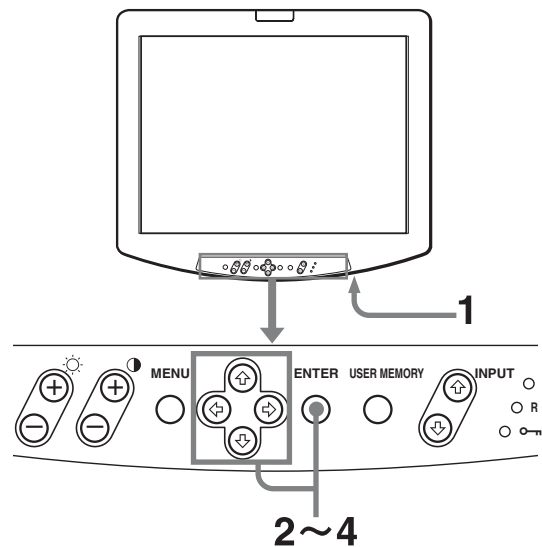

- 1 Press the POWER switch to turn on the unit.
The power is turned on and the SELECT SETTING screen appears.

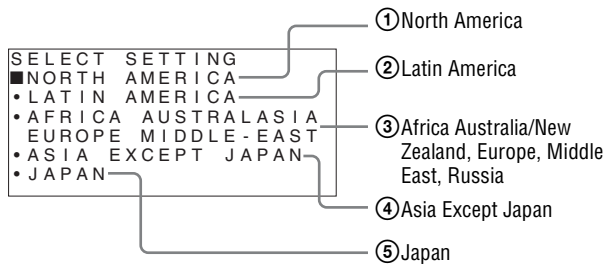

- 2 Press the **↑** or **↓** key to select the area where you intend to use the unit and press the ENTER key.

If you select either ①, ③ or ⑤

The confirmation screen is displayed. Confirm the selected area. When the setting is wrong, press the MENU key to return to the previous screen.

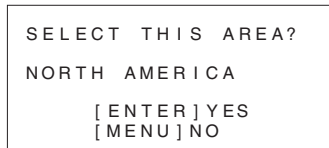

If you select either ② or ④

One of the following screens appears. Press the **↑** or **↓** key to narrow the area further and then press the ENTER key.

The confirmation screen is displayed. Confirm the selected area. When the setting is wrong, press the MENU key to return to the previous screen.

② If LATIN AMERICA is selected:

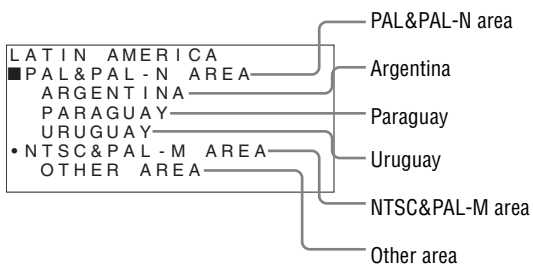

- ④ **If ASIA EXCEPT JAPAN is selected:**
Customers who will use this unit in the shaded areas shown in the map below should select NTSC AREA.
Other customers should select PAL AREA.

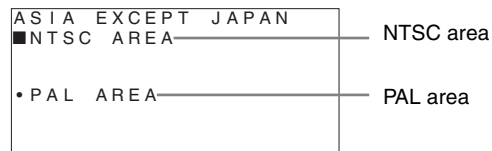

- 3 Press the ENTER key.
The area setting is executed and the COMPLETED screen is displayed.

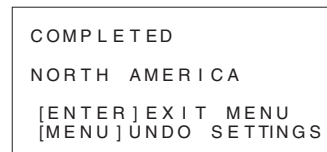

Press the MENU key to return to previous screen and undo settings.

- 4 Press the ENTER key.
The COMPLETED screen is disappeared and the default setting is completed.

Note

When you have selected the wrong area, set the following items using the menu.

- COLOR TEMP (on page 30)
- COMP LEVEL (on page 35)
- NTSC SETUP (on page 35)

See “The default setting values for each area” (on page 24)

Selecting the Menu Language

You can select one of seven languages (English, German, French, Italian, Spanish, Japanese, Chinese) for displaying the menu and other on-screen displays. "ENGLISH (English)" is selected in the default setting. The current settings are displayed in place of the ■ marks on the illustrations of the menu screen.

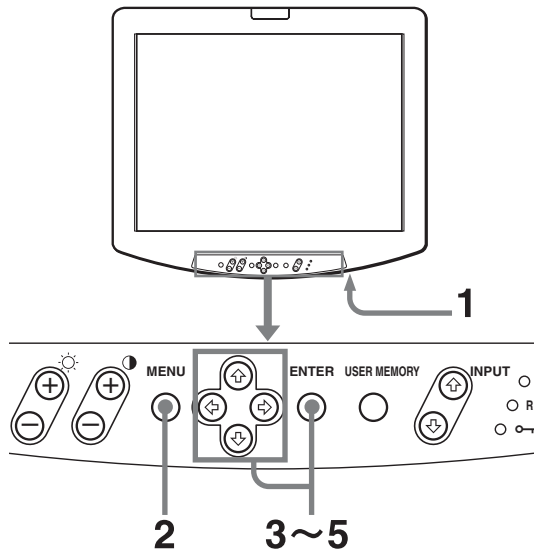

- 1 Press the POWER switch to turn on the unit.
- 2 Press the MENU key.
The menu appears.

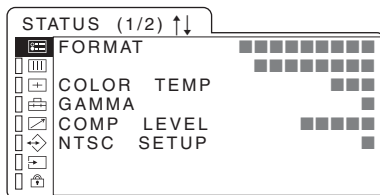

- 3 Press the ↑ or ↓ key to select the USER CONFIG 1/2 (User Configuration 1/2) menu, then press the → or ENTER key.
The setting items (icons) in the selected menu are displayed in yellow.

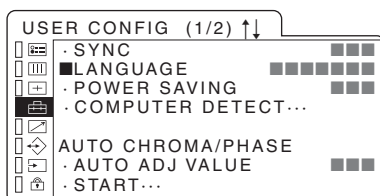

- 4 Press the ↑ or ↓ key to select "LANGUAGE", then press the → or ENTER key.
The selected item is displayed in yellow.
- 5 Press the ↑ or ↓ key to select a language, then press the ENTER key.
The menu changes to the selected language.

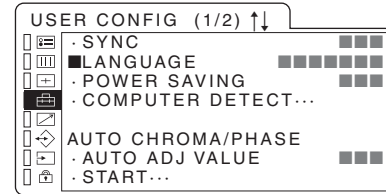

To clear the menu

Press the MENU key.
The menu disappears automatically if a key is not pressed for one minute.

Using the Menu

The unit is equipped with an on-screen menu for making various adjustments and settings such as picture control, input setting, set setting change, etc. You can also change the menu language displayed in the on-screen menu.

To change the menu language, see “Selecting the Menu Language” on page 26.

The current settings are displayed in place of the ■ marks on the illustrations of the menu screen.

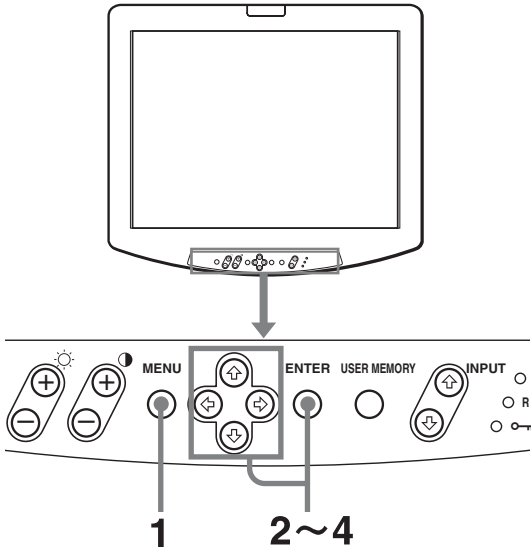

- 1 Press the MENU key.
The menu appears.

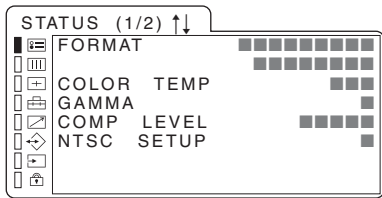

- 2 Use the ↑ or ↓ key to select a menu, then press the → or ENTER key.
The menu icon presently selected is shown in yellow and setting items are displayed.

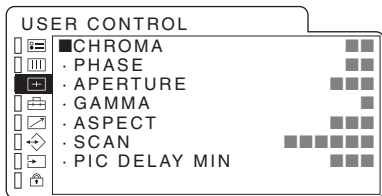

- 3 Select an item.
Use the ↑ or ↓ key to select the item, then press the → or ENTER key.
The item to be changed is displayed in yellow.

Note

If the menu consists of multiple pages, press ↑ or ↓ to go to the desired menu page.

- 4 Make the setting or adjustment on an item.
When changing the adjustment level:
To increase the number, press the ↑ key.
To decrease the number, press the ↓ key.
Press the ENTER key to confirm the number.

When changing the setting:
Press the ↑ or ↓ key to change the setting.
Press the ENTER key to confirm the setting.

Note

An item displayed in blue cannot be accessed. You can access the item if it is displayed in white.

To clear the menu

Press the MENU key.
The menu disappears automatically if a key is not pressed for one minute.

About the memory of the settings

The settings are automatically stored in the monitor memory.

To reset items that have been adjusted

Pressing the ↑ and ↓ keys simultaneously while you are adjusting any of the menu items resets the menu item to the previous setting.

Note

The operation may be different from the explanation above. Follow the explanation displayed at the lower part of the menu screen.

Loading USER MEMORY

You can load the picture settings saved in the USER MEMORY menu (on page 34).

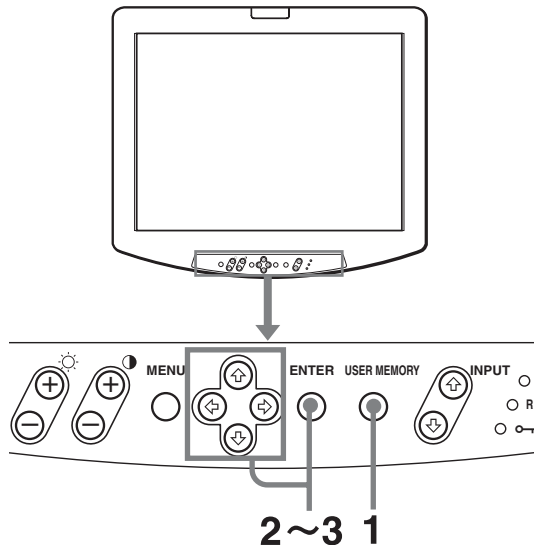

- 1 Press the “USER MEMORY” key.
The USER MEMORY menu appears.

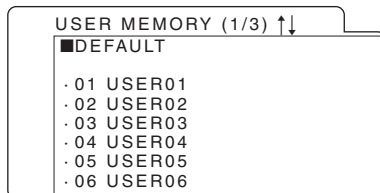

- 2 Select the memory number.
← or → key: to move the page
↑ or ↓ key: to select the memory number
- 3 Press the ENTER key.
After loading the picture settings from the selected memory, the menu disappears.

To stop selecting the memory

Press the USER MEMORY key.
The USER MEMORY menu disappears.

To reset the settings

Select “DEFAULT”, then press the ENTER key.

Adjustment Using the Menus

Items

STATUS (the items indicate the current settings.) (on page 29)

For the video input

FORMAT
COLOR TEMP
GAMMA
COMP LEVEL
NTSC SETUP
Model name and serial number
OPTION A and serial number
OPTION B and serial number

For the DVI/HD15 input

FORMAT
fH
fV
COLOR TEMP
GAMMA
Model name and serial number
OPTION A and serial number
OPTION B and serial number

COLOR TEMP (on page 30)

COLOR TEMP

USER CONTROL (on page 30)

CHROMA
PHASE
APERTURE
GAMMA
ASPECT
SCAN
PIC DELAY MIN

USER CONFIG (on page 32)

For the video input

SYNC
LANGUAGE
POWER SAVING
COMPUTER DETECT
AUTO CHROMA/PHASE
SHIFT H
SHIFT V
RESET

For the DVI/HD15 input

SYNC
LANGUAGE
POWER SAVING
COMPUTER DETECT
AUTO CHROMA/PHASE
SIZE H
SHIFT H
SHIFT V
DOT PHASE
RESET

REMOTE (on page 33)

PARALLEL REMOTE
SERIAL REMOTE

USER MEMORY (on page 33)

01-20

INPUT SELECT (on page 35)

ALL RESET
STANDARD INPUT
OPTION

KEY INHIBIT (on page 35)

KEY INHIBIT

USER SERVICE (on page 35)

FORMAT DISP
COMP LEVEL
NTSC SETUP
USER COLOR TEMP

Adjusting and Changing the Settings

STATUS menu

The STATUS menu is used to display the current status of the unit. The following items are displayed:

For the video input

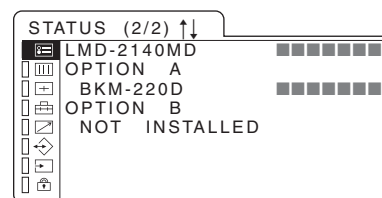
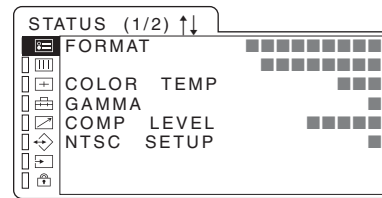

- FORMAT
- COLOR TEMP
- GAMMA
- COMP LEVEL
- NTSC SETUP
- Model name and serial number
- OPTION A and serial number
- OPTION B and serial number

For the DVI/HD15 input

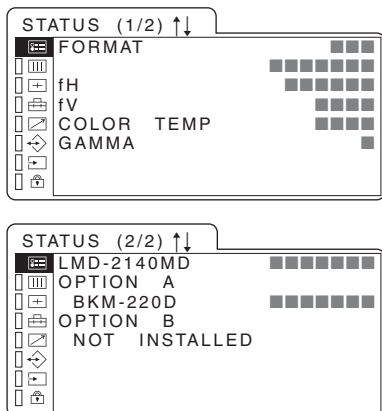

- FORMAT
- fH
- fV
- COLOR TEMP
- GAMMA
- Model name and serial number
- OPTION A and serial number
- OPTION B and serial number

COLOR TEMP menu

The COLOR TEMP menu is used for selecting the color temperature setting.

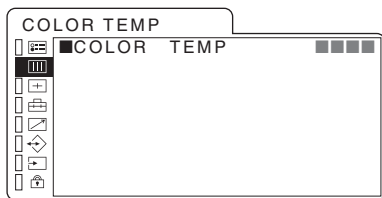

Submenu	Setting
COLOR TEMP	<p>Select the color temperature from among “HIGH”, “LOW”, “LOW2”, “LOW3” and “USER” settings.</p> <ul style="list-style-type: none"> • HIGH (D93 or equivalent) • LOW (D65 or equivalent) • LOW2 (D56 or equivalent) • LOW3 • USER: You can set to the color temperature adjusted in the USER SERVICE menu (on page 35). When the mode other than “USER” is selected, the color temperature cannot be adjusted in the USER SERVICE menu.

USER CONTROL menu

The USER CONTROL menu is used for adjusting the picture.

Items that cannot be adjusted depending on the input signal are displayed in blue.

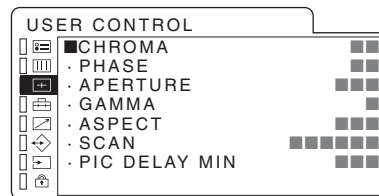

Submenu	Setting
CHROMA	Adjusts color intensity. The higher the setting, the greater the intensity. The lower the setting, the lower the intensity.
PHASE	Adjusts color tones. The higher the setting, the more greenish the picture. The lower the setting, the more purplish the picture.
APERTURE	Adjusts the picture sharpness. The higher the setting, the sharper the picture.
GAMMA	Selects the appropriate gamma mode. You can select from among 5 settings. When “3” is selected, the setting is roughly same as the gamma mode of the CRT (2.2).
ASPECT	<p>Sets the aspect ratio of the picture. When inputting 16:9 (squeezed) signal from equipment such as a DVD player, set to 16:9.</p> <ul style="list-style-type: none"> • 4:3: When the picture with ratio 4:3 is input. • 16:9: When the picture with ratio 16:9 (squeezed) is input.
SCAN	<p>Sets the scan size of the picture. Select from among “NORMAL”, “UNDER”, “OVER”, “ZOOM” and “NATIVE (NTSC, PAL, 480/60I and 575/50I only)” (see “Scan mode image” on page 31).</p>

Note

When inputting the 1035/60I signal, the signal format is displayed as 1080/60I on the screen. A slightly squashed picture is displayed at a little lower position, because the picture is displayed in 1035/1080 picture ratio on a 16:9 screen. Adjust the position to the center using the SHIFT V setting (on page 32).

Submenu	Setting
PIC DELAY MIN	<p>Selects to set the delay by the picture processing to the minimum level when the NTSC, PAL, 480/60I or 575/50I signal is input.</p> <ul style="list-style-type: none"> • 0: Mode for giving precedence to the picture quality (recommended mode). This is a mode suitable for an animation and a still picture. It takes longer than “1” or “2” for processing the picture. • 1: The processing time is short and this is a mode suitable for an animation. • 2: The processing time is short and this is a mode suitable for a still picture.

Scan mode image

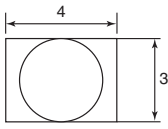
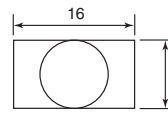
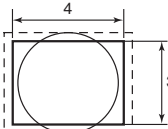
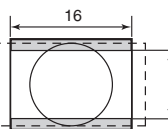
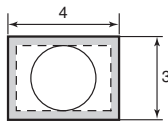
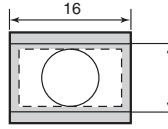
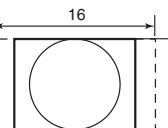
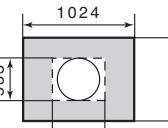
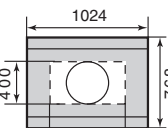
		Input	
			
Image displayed*1	NORMAL/ OVER SCAN*2		
	UNDER SCAN*3		
	ZOOM	-	
	NATIVE*4		

*1 The image illustrated shows the input signal by broken line and the efficient picture size by the solid line.

*2 NORMAL: 7% over scan
OVER: 20% over scan

*3 -3% under scan

*4 NTSC, PAL, 480/60I and 575/50I signals are displayed in the same size image. (The illustrations show the image when 480/60I signals are input.)

USER CONFIG menu

You can select a language, etc.

The item that cannot be accessed according to the input signal is displayed in blue.

For the video input

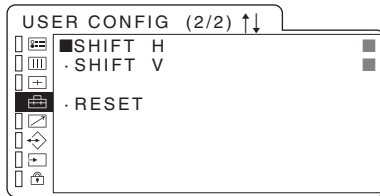
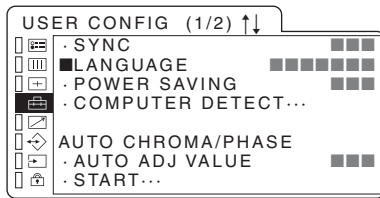

For the DVI/HD15 input

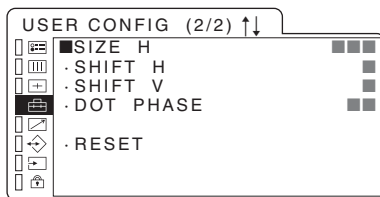
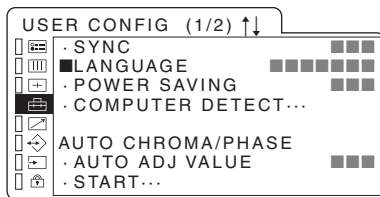

Submenu	Setting
SYNC	Select the sync signal. <ul style="list-style-type: none"> • EXT: Select to operate the unit on an external sync signal. When the RGB signal is input, "EXT" is the default setting. • INT: Select to operate the unit on the sync signal included in the monitored signal.
LANGUAGE	You can select the menu or message language from among seven languages. <ul style="list-style-type: none"> • ENGLISH: English • DEUTSCH: German • FRANÇAIS: French • ITALIANO: Italian • ESPAÑOL: Spanish • 日本語: Japanese • 中文: Chinese

Submenu	Setting
POWER SAVING	Sets the power saving mode "ON" or "OFF". When set to "ON", the monitor goes into power saving mode if no signal is input for about one minute.
COMPUTER DETECT...	The appropriate preset memory is set for the signal from DVI and HD15 input connector. Select "PRESET1" for the standard PC signal. Select "PRESET2", "PRESET3" or "PRESET4" when the PC signal is not standard (on page 41). The preset memory is set for each input connector of DVI and HD15.
AUTO CHROMA/PHASE	Adjusts color intensity (CHROMA) and tones (PHASE). <ul style="list-style-type: none"> • AUTO ADJ VALUE: Selects "ON" or "OFF" of the Auto adjustment. When set to "OFF", this parameter is reset to the factory setting. When set to "ON" the automatically adjusted value is enabled. • START...: Display the color bar signals (Full/SMPTE/EIA) on the screen and press the ENTER key. The auto adjustment function starts. After the adjustment is done correctly, the AUTO ADJ VALUE is automatically set to ON. The auto adjustment is stopped by pressing the MENU key during the auto adjustment operation.
SIZE H	Adjusts the horizontal size of the picture. The higher the setting, the larger the horizontal size of the picture. The lower the setting, the smaller the horizontal size of the picture.
SHIFT H	Adjusts the position of the picture. As the setting increases, the picture moves to the right, and as the setting decreases, the picture moves to the left.
SHIFT V	As the setting increases, the picture moves up, and as the setting decreases, the picture moves down.
DOT PHASE	Adjusts the dot phase. Adjust the picture further for a finer picture after the picture is adjusted by pressing the APA key.
RESET	Resets the value of SIZE H, SHIFT H, SHIFT V and DOT PHASE to the factory preset value.

REMOTE menu

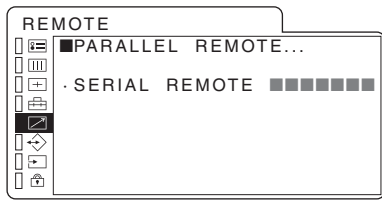

Submenu	Setting
PARALLEL REMOTE	<p>Select the REMOTE connector pins for which you want to change the function. You can assign various functions to 1 to 4 pins and 6 to 8 pins. The following lists the functions you can assign to the pins.</p> <ul style="list-style-type: none"> • -- (“--”: No function is assigned.) • COMPOSITE • Y/C • RGB • COMPONENT • DVI • HD15 • OPTION A-1 • OPTION A-2 • OPTION B-1 • OPTION B-2 • UNDERSCAN • OVERSCAN • ZOOM • NATIVE • 4:3 • 16:9 • TALLY • EXT SYNC (External Sync)

Notes

- If you use the parallel remote function, you need to connect cables. For more details, see page 38.
- When “OFF” is selected in the INPUT SELECT menu and the function is assigned, the remote function does not work. Select “ON” to use the parallel remote function (on page 35).

Submenu	Setting
SERIAL REMOTE	<p>Select one out of following three modes.</p> <ul style="list-style-type: none"> • RMT OFF: You cannot use the serial remote. Adjust settings by the keys on the front panel. • RMT ON: You can use the serial remote. You cannot use the keys except for the serial remote setting on the front panel. • RMT & LCL: You can use both the serial remote and the keys on the front panel.

Notes

- When “RMT ON” is selected, the REMOTE and  indicator on the front panel light.
- When “RMT & LCL” is selected, the REMOTE indicator lights.

USER MEMORY menu

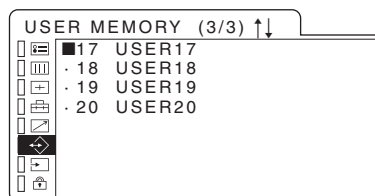
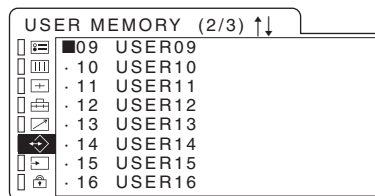
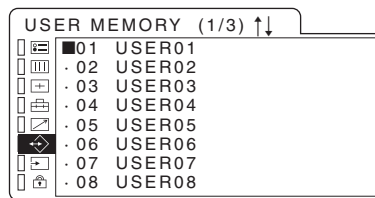

Submenu	Setting
01~20	<p>You can save the setting of the following functions.</p> <p>COLOR TEMP menu</p> <ul style="list-style-type: none"> • COLOR TEMP <p>USER CONTROL menu</p> <ul style="list-style-type: none"> • CHROMA • PHASE • APERTURE • GAMMA • ASPECT • SCAN • PIC DELAY MIN <p>USER SERVICE menu</p> <ul style="list-style-type: none"> • ADJUST GAIN • ADJUST BIAS <p>Front keys</p> <ul style="list-style-type: none"> • ☀ (Brightness) • ● (Contrast)

Saving the user memory

You can save the 20 picture settings with the name. To load the picture in the saved setting, see “Loading USER MEMORY” on page 28.

To save the picture setting

- 1 Press the **↑** or **↓** key to select the memory number in the USER MEMORY menu, then press the **➡** or ENTER key.
The USER MEMORY setting menu appears.

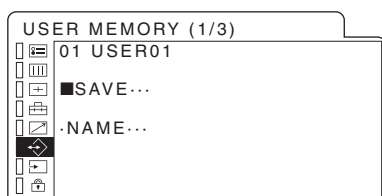

- 2 Select “SAVE”, then press the **➡** or ENTER key.
The menu for confirming the memory appears.

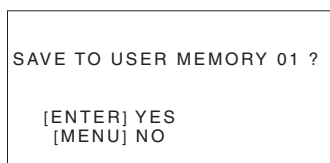

- 3 Press the ENTER key.
The current picture settings are saved and the USER MEMORY setting menu appears.

To close the menu without saving the setting

Press the **←** or MENU key.
The USER MEMORY setting menu appears.

To change the name

- 1 Press the **↑** or **↓** key to select the memory number in the USER MEMORY menu, then press the **➡** or ENTER key.
The USER MEMORY setting menu appears.

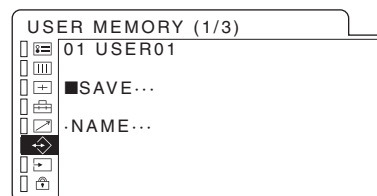

- 2 Press the **↓** key to select “NAME”, then press the **➡** or ENTER key.
The menu for setting the user name appears.

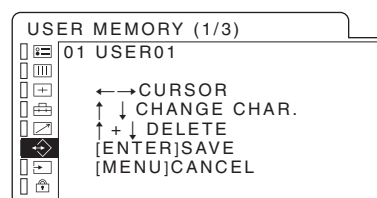

- 3 Change the user name.
 - Press the **←** or **➡** key to move the cursor to the character position to be changed.
 - Press the **↑** or **↓** key to change the character.
Usable characters: “A to Z”, “0 to 9”, “:”, “/”, “;”, “_”, “-”, “(space)”
 - Press the **↑** and **↓** keys simultaneously to clear the character.

The maximum 18 characters are input for the user name.
- 4 Press the ENTER key.
The settings are saved and the USER MEMORY setting menu appears.

To close the menu without saving the setting

Press the MENU key.
The USER MEMORY setting menu appears.

➔ INPUT SELECT menu

The input signal set to “OFF” is skipped when the INPUT \uparrow/\downarrow key is pressed.

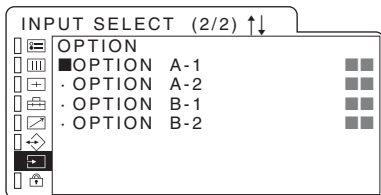
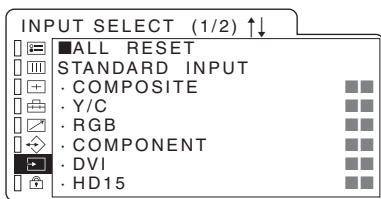

Submenu	Setting
ALL RESET	All settings are reset to the factory preset ones.
STANDARD INPUT	Sets the input setting of “COMPOSITE”, “Y/C”, “RGB”, “COMPONENT”, “DVI”, and “HD15”. <ul style="list-style-type: none"> • ON: Input signal is selectable. • OFF: Input signal is not selectable.
Note	
You cannot set all input settings to “OFF”.	
OPTION	Sets the input setting of an input adaptor. <ul style="list-style-type: none"> • ON: Input signal is selectable. • OFF: Input signal is not selectable.

🔒 KEY INHIBIT menu

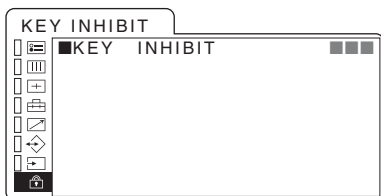

You can lock the setting so that they cannot be changed by an unauthorized user. Select “OFF” or “ON”. If you set to “ON”, all items are displayed in blue, indicating the items are locked. The keys only for setting the key inhibit to “OFF” work. When the key inhibit is set to “ON”, the Ⓚ indicator on the front panel lights.

Note

When “RMT ON” is selected in the REMOTE menu (on page 33), the Ⓚ indicator lights and the keys on the front panel do not work. However, “KEY INHIBIT” keeps set to “OFF”. When you want to operate the keys on the front panel, select “RMT OFF” or “RMT & LCL” in the REMOTE menu.

🔒 USER SERVICE menu

The USER SERVICE menu is provided for any adjustments or settings other than those listed above. To access the USER SERVICE menu, press and hold the MENU key when the menu is not displayed. The item that cannot be accessed according to the input signal is displayed in blue.

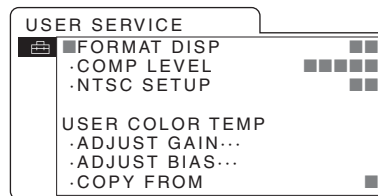

Submenu	Setting
FORMAT DISP	Select the display mode of the input signal and its format. <ul style="list-style-type: none"> • ON: Input signal and its format are always displayed. • OFF: Input signal and its format are not displayed. • AUTO: Input signal and its format are displayed for about 10 seconds, when the INPUT key is pressed, or the input of the signal begins.
COMP LEVEL	Select the component level from among three modes. <ul style="list-style-type: none"> • SMPTE for 100/0/100/0 signal • BETA 0 for 100/0/75/0 signal • BETA 7.5 for 100/7.5/75/7.5 signal
NTSC SETUP	Select the NTSC setup level from two modes. The 7.5 setup level is used mainly in North America. The 0 setup level is used mainly in Japan.
USER COLOR TEMP	Adjust the color temperature of “USER” which is selectable in the COLOR TEMP menu. When the color temperature other than “USER” is selected, this cannot be selected. You need to use the measurement instrument to adjust the white balance. Recommended: Konicaminolta color analyzer CA-210 <ul style="list-style-type: none"> • ADJUST GAIN...: Adjusts the color balance (GAIN). • ADJUST BIAS...: Adjusts the color balance (BIAS). • COPY FROM: If you select “HIGH”, “LOW”, “LOW2” or “LOW3”, the data for the selected color temperature will be copied in the user setting.

Troubleshooting

This section may help you isolate the cause of a problem and as a result, eliminate the need to contact technical support.

Symptom	Settlement
The display is colored in green or purple.	Select the correct input by pressing the INPUT key.
The black bars appear at the upper and lower positions of the picture.	When the signal aspect is different from that of the LCD panel, the black bars appear. This is not a failure of the unit.
The key on the front panel do not work.	The key protection function works. The key inhibit function can be set in the KEY INHIBIT menu and REMOTE menu. Set as follows. When "KEY INHIBIT" is set to "ON": Set to "OFF". When "SERIAL REMOTE" is set to "RMT ON": Set to "RMT OFF" or "RMT & LCL". When "KEY INHIBIT" and "SERIAL REMOTE" are set to "ON": Set "KEY INHIBIT" to "OFF" and then "SERIAL REMOTE" to "RMT OFF" or "RMT & LCL".
The image is not displayed on the monitor.	After confirming the connections and the settings in the INPUT SELECT menu (on page 35), select the correct input by pressing the INPUT key.
The image is disturbed.	Select "EXT" or "INT" correctly in the "SYNC" setting of the USER CONFIG menu (on page 32).
The "FAN ERROR" message is displayed.	The fan for cooling the unit does not work. Turn off the power and contact an authorized Sony dealer.

Specifications

Picture performance

LCD panel	a-Si TFT Active Matrix
Pixel efficiency	99.99 %
Viewing angle	(up/down/left/right, contrast > 10:1) 85°/85°/85°/85° (typical)
Scan	Under scan -3 % Normal 7 % Over scan 20 %
Efficient picture size	Approx. 430 × 322 × 537 mm (w/h/dia) (17 × 12 ³ / ₄ × 21 ¹ / ₄ inches)
Resolution	H: max. 1,024 dots V: max. 768 lines
Aspect ratio	4:3
Display color	Approx. 16,770,000

Input/output connectors

Input

Composite input connector	BNC type (1) 1 Vp-p ± 3dB sync negative
Y/C input connector	4-pin mini DIN (1) Y: 1 Vp-p ± 3dB sync negative C: 0.286 Vp-p ± 3dB (NTSC burst signal level) 0.3 Vp-p ± 3dB (PAL burst signal level)
RGB/Component connectors	BNC type (3) RGB input: 0.7 Vp-p ± 3dB (Sync On Green, 0.3 Vp-p sync negative) Component input: 0.7 Vp-p ± 3dB (75% chrominance standard color bar signal)
External Sync input connector	BNC type (1) 0.3 to 4 Vp-p ± bipolarity ternary or negative polarity binary
Remote input terminal	Parallel remote Modular connector 8-pin (1) RS-232C (serial remote) D-sub 9-pin (1)
HD15 input connector	HD D-sub 15-pin (1) R/G/B: 0.7 Vp-p, 75 ohms, sync positive (when G channel is sync negative, the internal sync can be used. 0.3 Vp-p)

Sync: TTL level, 2.2 kilohms, polarity free (H/V separate and composite sync)

Plug & Play function: corresponds to DDC2B

DVI input connector

DVI-D (1)

TMDS (Single link)

Output

Video output connectors

BNC type (4)

Loop-through, with 75 ohms automatic terminal function

4-pin mini DIN (1)

Loop-through, with 75 ohms automatic terminal function

External Sync output connector

BNC type (1)

Loop-through, with 75 ohms automatic terminal function

General

Power

AC100 to 240 V, 50/60 Hz,
1.2 A ~ 0.6 A

Power consumption

Maximum: approx. 100 W (when two BKM-255DV are attached)

Maximum: approx. 92 W (when no input adaptor is attached)

Peak inrush current

(1) Power ON, current probe method:
60 A (240 V)

(2) Hot switching inrush current,
measured in accordance with
European standard EN55103-1: 52
A (230 V)

Operating conditions

Temperature 0 °C to 40 °C (32 °F to 104 °F)

Recommended temperature

20 °C to 30 °C (68 °F to 86 °F)

Humidity 30 % to 85 % (no condensation)

Pressure 700 hPa to 1060 hPa

Storage and transport conditions

Temperature -10 °C to 40 °C (14 °F to 104 °F)

Humidity 0 % to 90 % (no condensation)

Pressure 700 hPa to 1060 hPa

Accessories supplied

AC power cord (1)

AC plug holder (2)

Instructions for Use (1)

CD-ROM (1)

Warranty Card (1)

Using the CD-ROM Manual (1)

Quick Reference (1)

When You First Use the Monitor (1)

Sales Companies Guide (1)

Optional accessories

SDI 4:2:2 input adaptor

BKM-220D

HD/D1-SDI input adaptor

BKM-243HS

DV input adaptor

BKM-255DV

NTSC/PAL input adaptor

BKM-227W

Analog Component input adaptor

BKM-229X

Monitor stand

SU-560

Medical Specifications

Protection against electric shock:

Class I

Protection against harmful ingress of water:

Ordinary

Degree of safety in the presence of flammable anesthetics mixture with oxygen:

Not suitable for use in the presence of flammable anesthetics mixture with oxygen

Mode of operation:

Continuous

Design and specifications are subject to change without notice.

Pin assignment

PARALLEL REMOTE terminal

Modular connector (8-pin)

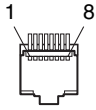

Pin No.	Signal
1	Designating Y/C input signal
2	Designating RGB input signal
3	Designating OPTION A-1 input signal
4	Designating OPTION A-2 input signal
5	GND
6	Tally lamp ON/OFF
7	Under scan
8	Over scan

You can allocate functions using the REMOTE menu (see page 33).

Connect the function you want to use with a Remote Control to the Ground (Pin 5).

SERIAL REMOTE (RS-232C) terminal

D-sub 9 pin, female

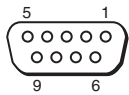

Pin No.	Signal
1	NC
2	RX
3	TX
4	NC
5	GND
6	NC
7	RTS
8	CTS
9	NC

Video signal formats

The unit is applicable to the following signal formats.

Input						
System	Total lines	Active lines	Frame rate* ²	Scanning format	Aspect ratio	Signal standard
575/50I (PAL)	625	575	25	2:1 interlace	16:9/4:3	EBU N10 (PAL: ITU-R BT.624)
480/60I (NTSC)	525	483	30	2:1 interlace	16:9/4:3	SMPTE 253M (NTSC: SMPTE 170M)
576/50P	625	576	50	Progressive	16:9/4:3	ITU-R BT.1358
480/60P	525	483	60	Progressive	16:9/4:3	SMPTE 293M
1080/50I	1125	1080	25	2:1 interlace	16:9	SMPTE 274M
1035/60I * ¹	1125	1035	30	2:1 interlace	16:9	SMPTE 260M/BTA S-001B
1080/60I	1125	1080	30	2:1 interlace	16:9	SMPTE 274M/BTA S-001B
720/60P	750	720	60	Progressive	16:9	SMPTE 296M

Output			
System	Effective picture size	Frame rate* ²	Scanning format
575/50I (PAL)	1024 × 576/1024 × 768	50	Progressive
480/60I (NTSC)	1024 × 576/1024 × 768	60	Progressive
576/50P	1024 × 576/1024 × 768	50	Progressive
480/60P	1024 × 576/1024 × 768	60	Progressive
1080/50I	1024 × 576	50	Progressive
1035/60I * ¹	1024 × 576	60	Progressive
1080/60I	1024 × 576	60	Progressive
720/60P	1024 × 576	60	Progressive

*1 The signal format is displayed as 1080/60I on the screen.

A slightly squashed picture is displayed at a little lower position, because the picture is displayed in 1035/1080 picture ratio on a 16:9 screen. Adjust the position to the center using the SHIFT V setting (on page 32).

*2 The frame rate is also compatible with 1/1.001.

When an optional input adaptor is installed

The unit is applicable to the following signal formats.

When BKM-220D/243HS is installed

Input			
System	Signal standard	BKM-220D	BKM-243HS
575/50I	ITU-R BT.656	○	○
480/60I	SMPTE 259M	○	○
1080/50I	SMPTE 292M	×	○
1035/60I *	SMPTE 292M	×	○
1080/60I	SMPTE 292M	×	○
720/60P	SMPTE 292M	×	○

When BKM-255DV is installed

Input		
System	Signal standard	BKM-255DV
575/50I	IEEE 1394-1995	○
480/60I	IEEE 1394-1995	○

When BKM-227W/229X is installed

Input			
System	Signal standard	BKM-227W	BKM-229X
575/50I	EBU N10	×	○
PAL	ITU-R BT.624	○	×
480/60I	SMPTE 253M	×	○
NTSC	SMPTE 170M	○	×
576/50P	ITU-R BT.1358	×	○
480/60P	SMPTE 293M	×	○
1080/50I	SMPTE 274M	×	○
1035/60I *	SMPTE 260M/BTA S-001B	×	○
1080/60I	SMPTE 274M/BTA S-001B	×	○
720/60P	SMPTE 296M	×	○

* A slightly squashed picture is displayed at a little lower position, because the picture is displayed in 1035/1080 picture ratio on a 16:9 screen. Adjust the position to the center using the SHIFT V setting (on page 32).

About the preset signal

This unit has the preset memory for the signals connected to the DVI and HD15 input terminals (the preset memory). When a preset signal is input, the unit automatically detects the signal type and recalls the data for the signal from the preset memory to adjust it to an optimum picture.

This unit is applicable to the following preset signals.

PRESET1

	Preset signal		fH [kHz]	fV [Hz]
HD15	640×480	VGA mode 3	31.5	60
		VGA VESA 72Hz	37.9	72
		VGA VESA 75Hz	37.5	75
		VGA VESA 85Hz	43.3	85
		VGA Non-CRT	29.5	60
	800×600	SVGA VESA 60Hz	37.9	60
		SVGA VESA 72Hz	48.1	72
		SVGA VESA 75Hz	46.9	75
		SVGA VESA 85Hz	53.7	85
		SVGA Non-CRT	37.0	60
	1024×768	XGA VESA 60Hz	48.4	60
		XGA VESA 70Hz	56.5	70
		XGA VESA 75Hz	60.0	75
		XGA VESA 85Hz	68.7	85
		XGA Non-CRT	47.3	60
	1280×1024*	SXGA VESA 60Hz	64.0	60
		SXGA Non-CRT	63.2	60
	720×400	VGA TEXT	31.5	70
DVI	640×480	VGA VESA 60Hz	31.5	60
	1024×768	XGA VESA 60Hz	48.4	60
	1280×1024*	SXGA VESA 60Hz	64.0	60

VGA, SVGA, XGA, and SXGA are registered trademarks of International Business Machines Corporation, U.S.A.

* SXGA is a down convert display.

PRESET2

	Preset signal	fH [kHz]	fV [Hz]
HD15	1514×483*	31.5	60
	1476×576*	31.3	50
DVI	1280×483*	31.5	60
	1280×576*	31.3	50

PRESET3

	Preset signal	fH [kHz]	fV [Hz]
HD15	720×483	31.5	60
	720×576	31.3	50
	1280×720*	45.0	60
	1280×720*	37.5	50
DVI	720×483	31.5	60
	720×576	31.3	50
	1280×720*	45.0	60
	1280×720*	37.5	50

PRESET4

	Preset signal	fH [kHz]	fV [Hz]
HD15	640×480	31.5	60
	1024×768	48.4	60
	1280×960*	60.0	60
DVI	640×480	31.5	60
	1024×768	48.4	60
	1280×960*	60.0	60

* Down convert display.

Dimensions/Mass

Front

When an optional stand SU-560 is attached

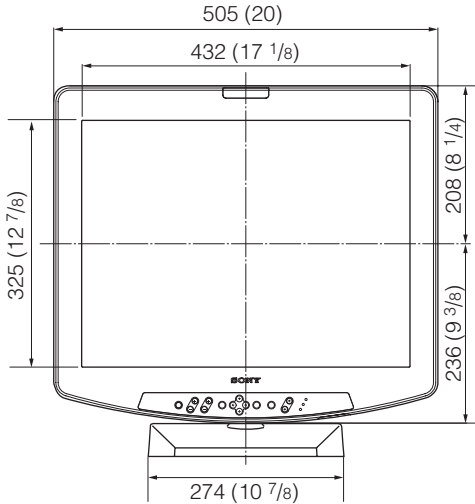

Top

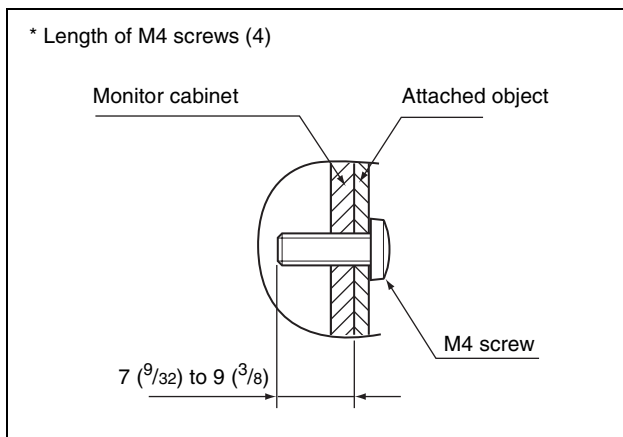
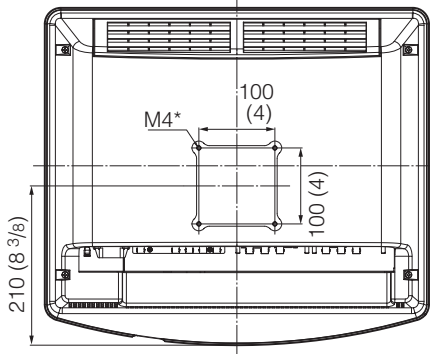

Side

When an optional stand SU-560 is attached

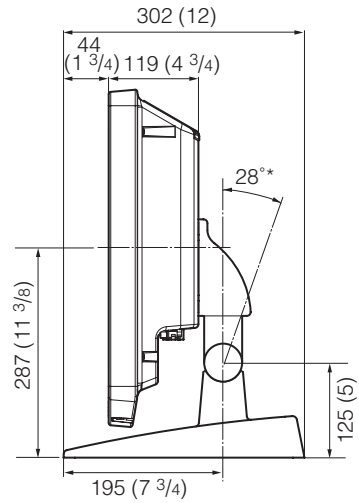

Unit: mm (inches)

*Tilt angle

Mass

Approx. 9.3 kg (20 lb 8 oz)

(When no input adaptor is attached)

Approx. 9.8 kg (21 lb 10 oz)

(When two BKM-255DV are attached)

